



INSTRUCTION BULLETIN

No. 9007144
Machine: M20, T20,
M30
Published: 08-2015
Rev. 01

NOTE: DO NOT DISCARD the Parts List from the Instruction Bulletin. Place the Parts List in the appropriate place in the machine manual for future reference. Retaining the Parts List will make it easier to reorder individual parts and will save the cost of ordering an entire kit.

NOTE: Numbers in parenthesis () are reference numbers for parts listed in Bill of Materials.

Installation instructions for **kit number 9007142 (M20 & T20) / 9007143 (M30)**

SYNOPSIS:

This kit contains the parts needed to replace the auxiliary hydraulic pump on M20 (serial numbers 000000- 003297), T20 (serial numbers 000000- 002282), and M30 (serial numbers 000000- 001462) machines.

Please follow step-by-step instructions.

SPECIAL TOOLS / CONSIDERATIONS: NONE

(Estimated time to complete: 2 hours)

When assembling/disassembling hydraulic components:

1. Thoroughly clean outside of hydraulic components **before** disconnecting hydraulic hoses or fittings and flush hoses and fittings with air, solvent, or hydraulic fluid and cap disconnected hoses or open ports to prevent contaminants from entering system.
2. Mark hydraulic hoses with locations of where they are connected. Markings make it easier to reconnect hoses to proper locations.
3. Discard all hydraulic fluid drained from the system. Use only new approved hydraulic fluid to replenish hydraulic reservoir. Hydraulic fluid is potentially dangerous to the environment. Obey all federal, state, and local laws/regulations governing the disposal of environmentally hazardous materials when disposing hydraulic fluid.

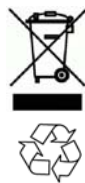

PROTECT THE ENVIRONMENT

Please dispose of packaging materials, used machine components such as batteries and fluids in an environmentally safe way according to local waste disposal regulations.

Always remember to recycle.

PREPARATION:

1. Park the machine on a clean level surface, turn off the machine, remove the key, and set the parking brake.

2. Open or remove the engine cover.
3. Remove any components / rearrange hoses necessary to make access to the hydraulic gear pump easier.

FOR SAFETY: Before leaving or servicing machine, stop on level surface, turn off machine, and remove key.

INSTALLATION:

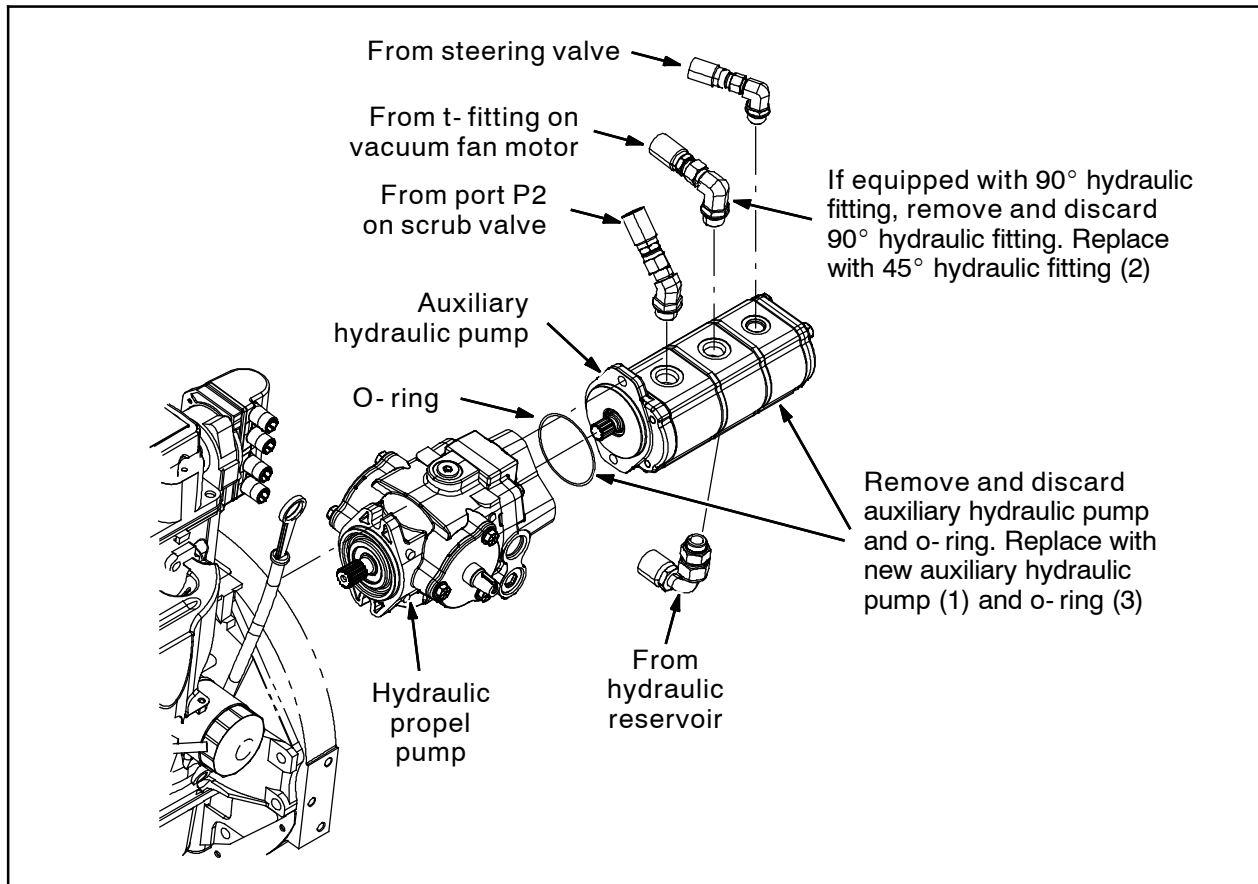

FIG. 1

1. Disconnect all the hydraulic hoses from the auxiliary hydraulic pump on the hydraulic propel pump. (Fig. 1)
2. Remove the auxiliary hydraulic pump from the hydraulic propel pump. Discard the auxiliary hydraulic pump and o-ring. (Fig. 1)
3. Disconnect the 90° fitting from the hose connected to the t-fitting on the vacuum fan motor. Discard the 90° fitting. (Fig. 1)
4. Install the 45° fitting (2) onto the hose from the t-fitting on the vacuum fan motor. (Fig. 1)
5. Apply a light coat of grease onto the o-ring (3).
6. Install the new o-ring (3) into the new auxiliary hydraulic pump (3). Refer to Fig. 1.
7. Install the new auxiliary hydraulic pump (2) onto the hydraulic propel pump. Take care to not damage the o-ring (3) when installing the auxiliary hydraulic pump onto the hydraulic propel pump. (Fig. 1)
8. Install the hose connected to the t-fitting on the vacuum fan motor to the first stage on the auxiliary hydraulic pump (1). (Fig.1 / Fig. 2)
9. Connect the hose from port P2 on the scrub valve to the second stage on the auxiliary hydraulic pump (1). (Fig.1 / Fig. 2)
10. Connect the hoses from the hydraulic reservoir and front wheel drive motor to the auxiliary hydraulic pump (1). (Fig. 1 / Fig. 2)
11. Reinstall any components removed to make installing the new auxiliary hydraulic pump (1) easier. (Fig. 1)
12. Replenish the hydraulic system with fresh hydraulic fluid.
13. Start and test the machine. Observe for hydraulic leaks around areas where hydraulic connections were broken, moved, or components replaced.

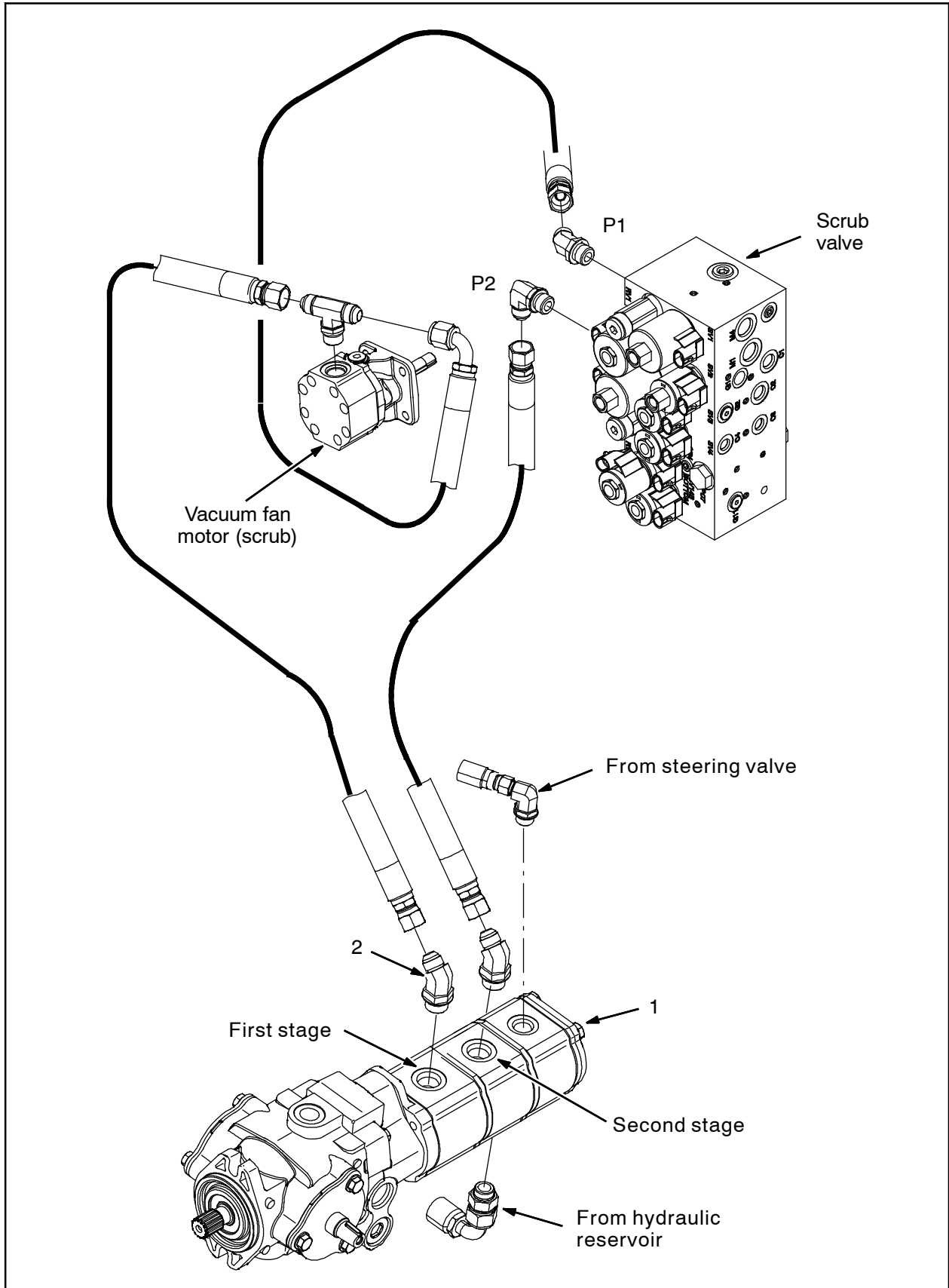

FIG. 2

Bill Of Materials For Pump Kit, Mtg, Aux, CI [M20 & T20] - 9007142

	Ref.	Tennant Part No.	Description	Qty.
▽		9007142	Pump Kit, Mtg, Aux, CI [M20 & T20]	1
▲	1	1059195	Pump, Hyd, Gear, Ext, 3, 00.97 2500, CW	1
▲	2	47513	Fitting, Hyd, E45, JM08 / OM10	1
▲	3	65245- 1	Seal, Org, .069 X 3.06ID	1

Bill Of Materials For Pump Kit, Mtg, Aux, CI [M30] - 9007143

	Ref.	Tennant Part No.	Description	Qty.
▽		9007143	Pump Kit, Mtg, Aux, CI [M30]	1
▲	1	1059196	Pump, Hyd, Gear, Ext, 3, 00.85 2500, CW	1
▲	2	47513	Fitting, Hyd, E45, JM08 / OM10	1
▲	3	65245- 1	Seal, Org, .069 X 3.06ID	1

TENNANT COMPANY
P. O. Box 1452
Minneapolis, MN 55440-1452